

User Guide

Le Guide de l'Utilisateur

Bedienungsanleitung

Guida dell'Utente

Instrucciones de Uso

Manual do Usuário

Руководство пользователя

取扱説明書

사용자 안내서

用戶指南

# KSM8

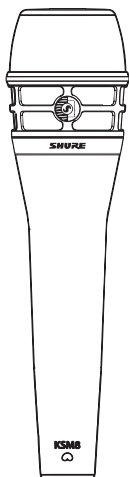



# SHURE INCORPORATED

## KSM8

Thank you for selecting the KSM series from Shure.



Over 90 years of audio experience has contributed to making this one of the finest microphones available.

If you have any questions not answered in this guide, please contact Shure Applications Engineering at 847-600-8440, Monday through Friday, from 8:00 am to 4:30 pm, CST. In Europe, call 49-7262-92490. In Asia, call 852-2893-4290. Our web address is [www.shure.com](http://www.shure.com).

# KSM8 Dualdyne™ Microphone

## General Description

The Shure KSM8 Dualdyne™ Microphone is the world's first handheld dual-diaphragm dynamic microphone, designed for professional vocal applications in live sound and studio environments. Shure has taken dynamic microphone technology and performance to a groundbreaking new level with the development of the premium KSM8 Dualdyne. By achieving greater output level while minimizing proximity effect to an unmatched degree, the microphone provides a clean, richly detailed signal with minimal feedback. With state-of-the-art manufacturing from superior components, each KSM8 Dualdyne is meticulously crafted and tested to uphold the quality standards of world-class Shure construction even in the most demanding live environments.

## Model Variations

The KSM8 microphone is available in a black or brushed-nickel finish. It may also be purchased as part of a Shure wireless system, or as an upgrade to an existing wireless handheld transmitter.

**KSM8/B:** Superior dual-diaphragm dynamic microphone with a black finish.

**KSM8/N:** Superior dual-diaphragm dynamic microphone with a brushed-nickel finish.

## Features

This dual-diaphragm cartridge delivers greater consistency across the frequency spectrum as the distance between the microphone and the source changes. This revolutionary technology provides the following benefits:

- Reduced proximity effect
- Clean, natural low end
- Smooth high frequency response without a pronounced presence peak
- Increased working distance

### Premium Components

The KSM8 delivers exceptional results and withstands the rigors of daily use in the most demanding live sound environments.

- Advanced internal pneumatic shock mount and the Diaphragm Stabilization System (DSS™ patent pending) work together to prevent handling noise
- True cardioid pattern prevents feedback and provides consistent off-axis response
- Hardened, dent resistant grille lined with hydrophobic woven fabric that rejects moisture as well as pliosives for years of high quality use

## Care and Maintenance

The KSM8 grille is lined with a permanently-attached hydrophobic cloth. The user should not attempt to remove or replace this lining. The exterior of the grille can be cleaned by gently using warm soap and water with a soft toothbrush.

If the grille becomes damaged or deformed, please contact Shure's Service Department for a replacement.

**Warning:** Turning the cartridge in the shockmount or touching the second diaphragm can result in permanent microphone damage and may result in an undesirable change in frequency response. There are no user-serviceable parts inside.

## Applications

The KSM8 Dualdyne is designed to excel as a vocal microphone while withstanding the punishment of professional live sound reinforcement, but can be used to capture other sources as well. For information on microphone use and applications or for a more comprehensive look at the technology behind the microphone, visit [www.shure.com](http://www.shure.com) for educational publications on these topics and more:

- Microphone techniques for live sound reinforcement
- Microphone techniques for recording
- Proximity effect

## The Shure Dualdyne™ Cartridge

The KSM8 Dualdyne™ Cartridge utilizes a reversed side entry airflow system. Sound enters the microphone via the side entry inlets and passes through the rear second diaphragm before striking the front diaphragm. By using the second diaphragm in the resistance network low frequencies are partially blocked from entering the cartridge resulting in a natural, low-end response with controlled proximity effect and no loss in clarity.

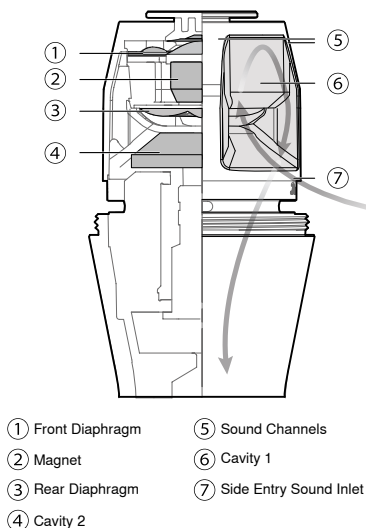

Dualdyne cartridge side view

### Reduced Proximity Effect

With traditional microphones, low-frequency response increases as the performer moves closer to the microphone. A strong presence peak centered around 4 to 5 kHz is used to counteract the increased bass.

The dual-diaphragm microphone greatly reduces the proximity effect, and low-frequency response remains consistent with distance. This delivers a more natural response throughout the vocal range, eliminating the need for a strong presence peak.

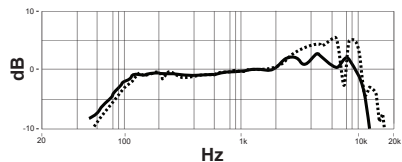

..... single diaphragm      — dual-diaphragm

Single vs. Dual-diaphragm frequency response

## Dualdyne™ Benefits

The unique design of the Shure Dualdyne™ cartridge provides several benefits over traditional single-diaphragm dynamic microphones:

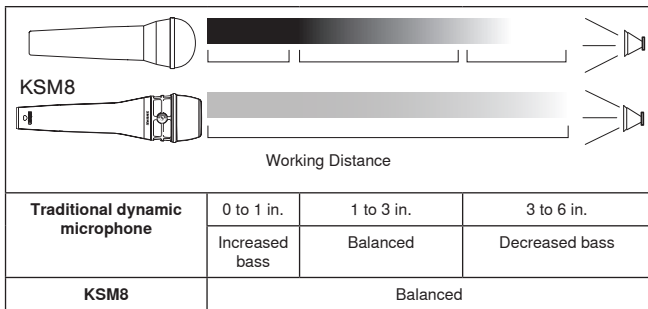

### Increased Working Distance

Traditional microphones confine the performer to a specific distance from the microphone. They must maintain this distance in order to avoid variations in tone.

The balanced response of the dual-diaphragm microphone allows the performer to move more freely without affecting the sound quality.

### Less Signal Processing Required

Live sound engineers often use signal processing, like equalization, to mitigate both the proximity effect of traditional microphones or to compensate for improper microphone technique (such as when a performer covers the grille with their hand).

The dual-diaphragm microphone delivers a smoother response throughout the vocal range and is less susceptible to improper microphone handling, requiring less corrective signal processing and resulting in a more natural sound.

### Exceptional Off-axis Linearity

When unwanted off-axis sources leak into vocal microphones, it can degrade phase coherency and compromise source quality. The KSM8 provides greater immunity to these problems, due to linear polar response across the entire frequency spectrum.

## Design and Construction

The mechanical design of the KSM8 offers advancements that benefit the performance and aesthetics of the microphone.

### Advanced Pneumatic Shockmount Technology

The Diaphragm Stabilization System (DSS™) works with the pumping pneumatic shockmount to isolate and suspend the cartridge, reducing handling noise. In addition to diminishing unwanted movement, the moving piston and internal cavities have been precisely engineered to stabilize the diaphragm amidst mechanical vibration. The Shure engineers originally patented this technology over 50 years ago, and Shure is the only microphone manufacturer to successfully implement it.

### Innovative Hardened Grille Design

The outer grille has been tempered to provide years of dent resistance. The grille interior is lined with a hydrophobic woven fabric. This moisture-resistant cloth protects the cartridge while providing superior pop protection, ensuring years of usability and durability.

## Accessories

### Furnished Accessories

Black, Soft Flex Swivel Stand Adapter for KSM8 and KSM9	A25E
Zippered Carrying Case for KSM8	AK8C
5/8" to 3/8" (Euro) Threaded Adapter	95A2050

### Optional Accessories

Black Foam Windscreen for KSM8, SM85, SM86, SM87A, Beta 87A, and Beta 87C	A85WS
---	-------

### Replacement Parts

Black Replacement Grille for KSM8 Wired and Wireless	RPM266
Brushed Nickel Replacement Grille for KSM8 Wired and Wireless	RPM268

## Certifications

This product meets the Essential Requirements of all relevant European directives and is eligible for CE marking.

The CE Declaration of Conformity can be obtained from: [www.shure.com/europe/compliance](http://www.shure.com/europe/compliance)

Authorized European representative:

Shure Europe GmbH

Headquarters Europe, Middle East & Africa

Department: EMEA Approval

Jakob-Dieffenbacher-Str. 12

75031 Eppingen, Germany

Phone: 49-7262-92 49 0

Fax: 49-7262-92 49 11 4

Email: [info@shure.de](mailto:info@shure.de)

# Specifications

## Type

Dual Diaphragm Dynamic (moving coil)

## Frequency Response

40 to 16,000 Hz

## Polar Pattern

Cardioid

## Output Impedance

300  $\Omega$

## Sensitivity

at 1 kHz, open circuit voltage

-51.5 dBV/Pa[1] (1.85 mV)

## Polarity

Positive pressure on diaphragm produces positive voltage on pin 2 with respect to pin 3

## Net Weight

330 g (11.64oz.)

## Connector

Three-pin professional audio (XLR), male

## Housing

Die-cast Aluminum with Paint or Brushed Nickel Finish

[1] 1 Pa=94 dB SPL

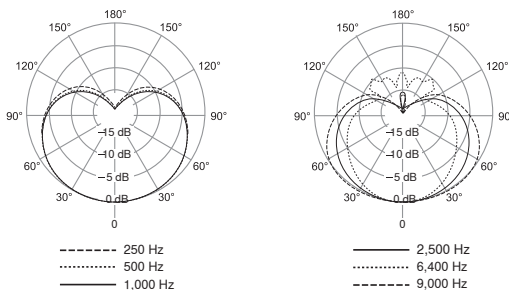

Polar Pattern

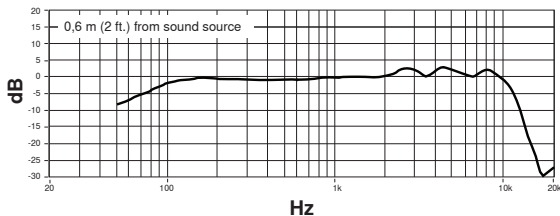

Frequency Response

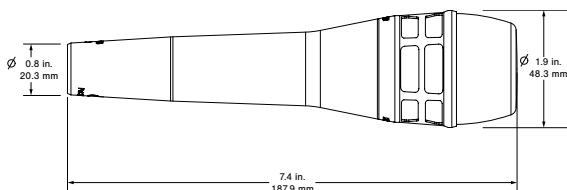

Dimensions





Trademark Notices: The circular S logo, the stylized Shure logo, and the word, "Shure" are registered trademarks of Shure Incorporated in the United States. "SHOCKSTOPPER" is a trademark of Shure Incorporated in the United States. "Mylar" is a registered trademark of E.I. DuPont de Nemours and Company in the United States. These marks may be registered in other jurisdictions.

Patent Notice: Patent Des. 530 706 Des. 531 171

**SHURE**<sup>®</sup>

**United States, Canada, Latin America, Caribbean:**

Shure Incorporated  
5800 West Touhy Avenue  
Niles, IL 60714-4608 USA

Phone: +1-847-600-2000  
Fax: +1-847-600-1212 (USA)  
Fax: +1-847-600-6446  
Email: [info@shure.com](mailto:info@shure.com)

**Europe, Middle East, Africa:**

Shure Europe GmbH  
Jakob-Dieffenbacher-Str. 12,  
75031 Eppingen, Germany

Phone: +49-7262-92490  
Fax: +49-7262-9249114  
Email: [info@shure.de](mailto:info@shure.de)

**Asia, Pacific:**

Shure Asia Limited  
22/F, 625 King's Road  
North Point, Island East  
Hong Kong

Phone: 852-2893-4290  
Fax: 852-2893-4055  
Email: [info@shure.com.hk](mailto:info@shure.com.hk)

[www.shure.com](http://www.shure.com)