



R193

Replacement Cartridge

Shure online user guide for R193 replacement cartridge.
Version: 3.0 (2020-G)

Table of Contents

R193Replacement Cartridge	3	Installation Guide	3
		Certifications	7

R193 Replacement Cartridge

Installation Guide

Use the following instructions to replace the cartridge in Shure Beta 87 condenser microphones.

1. Remove the microphone grille by unscrewing it in a counterclockwise direction.

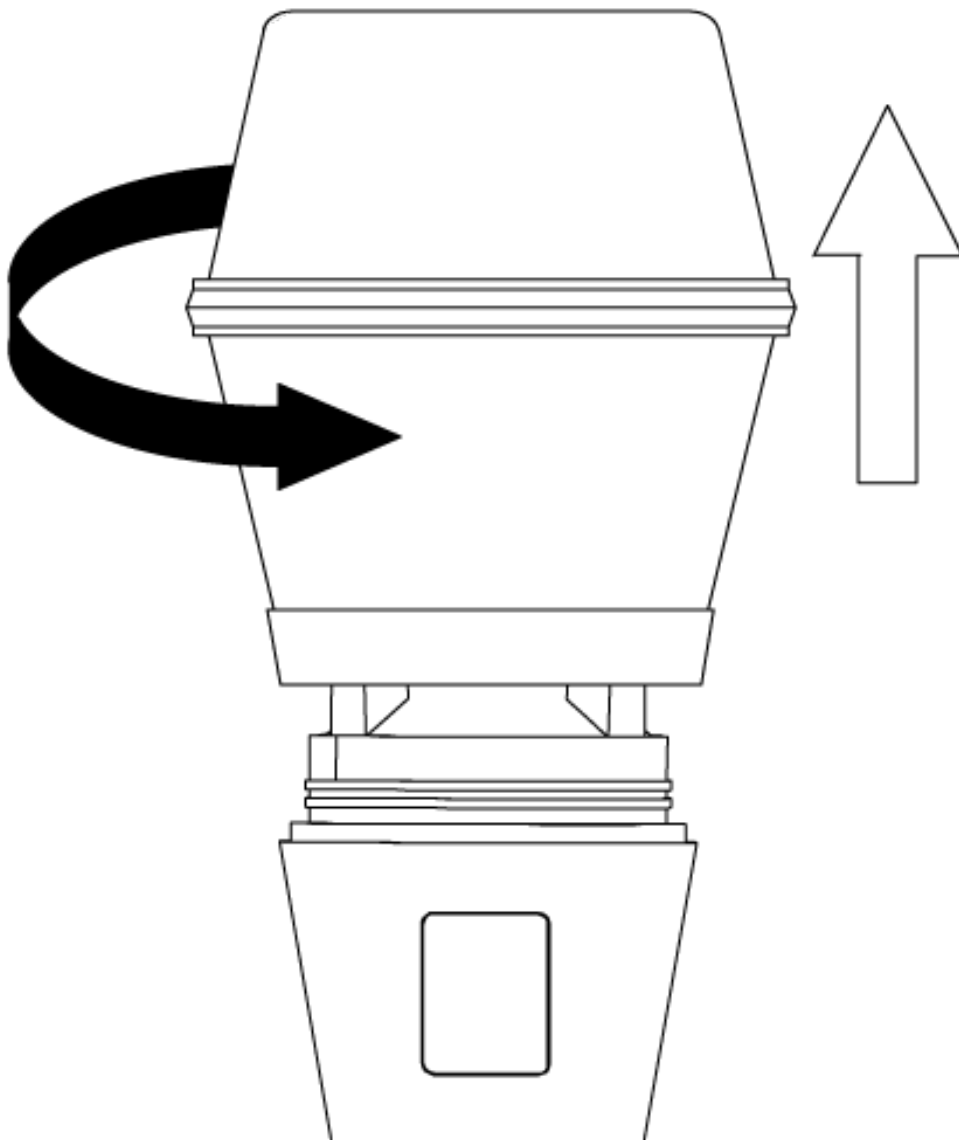

- Using tweezers or small needle-nosed pliers, grasp the pins at the end of the blue and green leads and gently unplug them from the cartridge.

Be careful when handling the lead wires, as they may easily come loose from the pins.

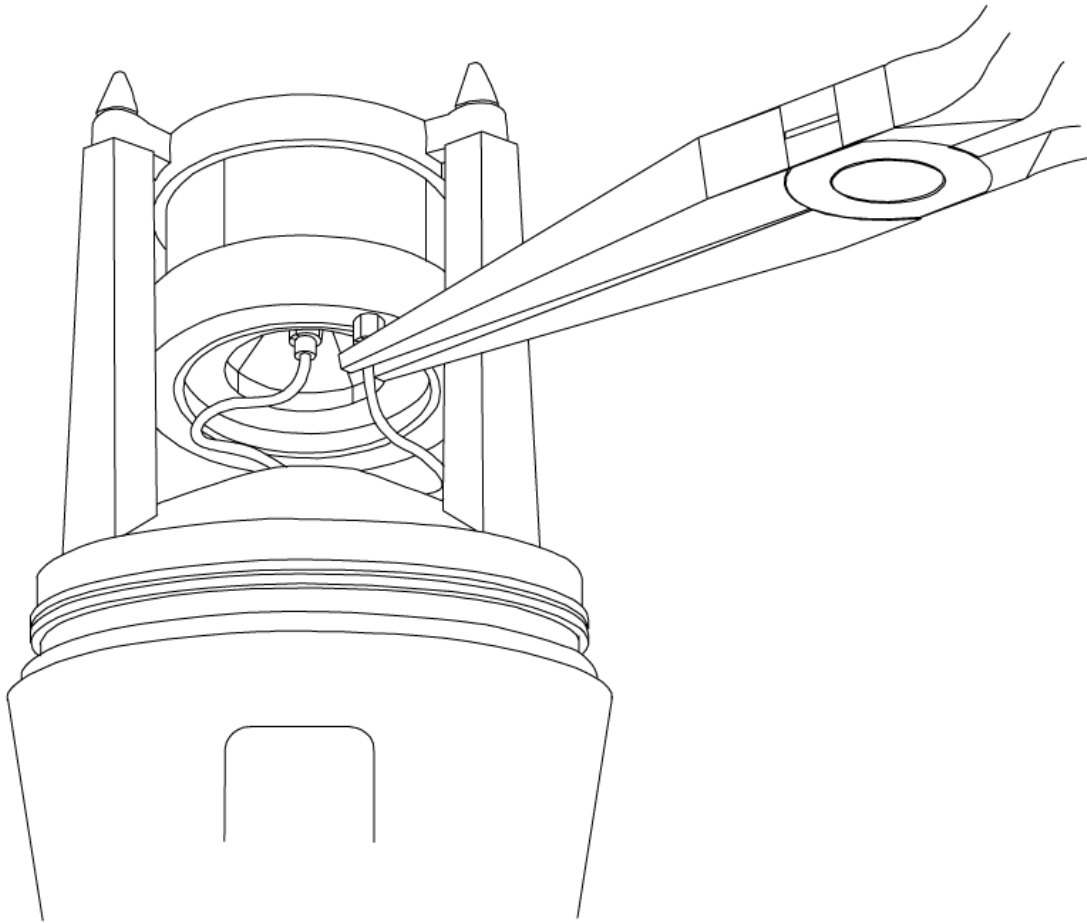

- Remove the old cartridge by pulling off the rubber loops from the three shock-mount posts.

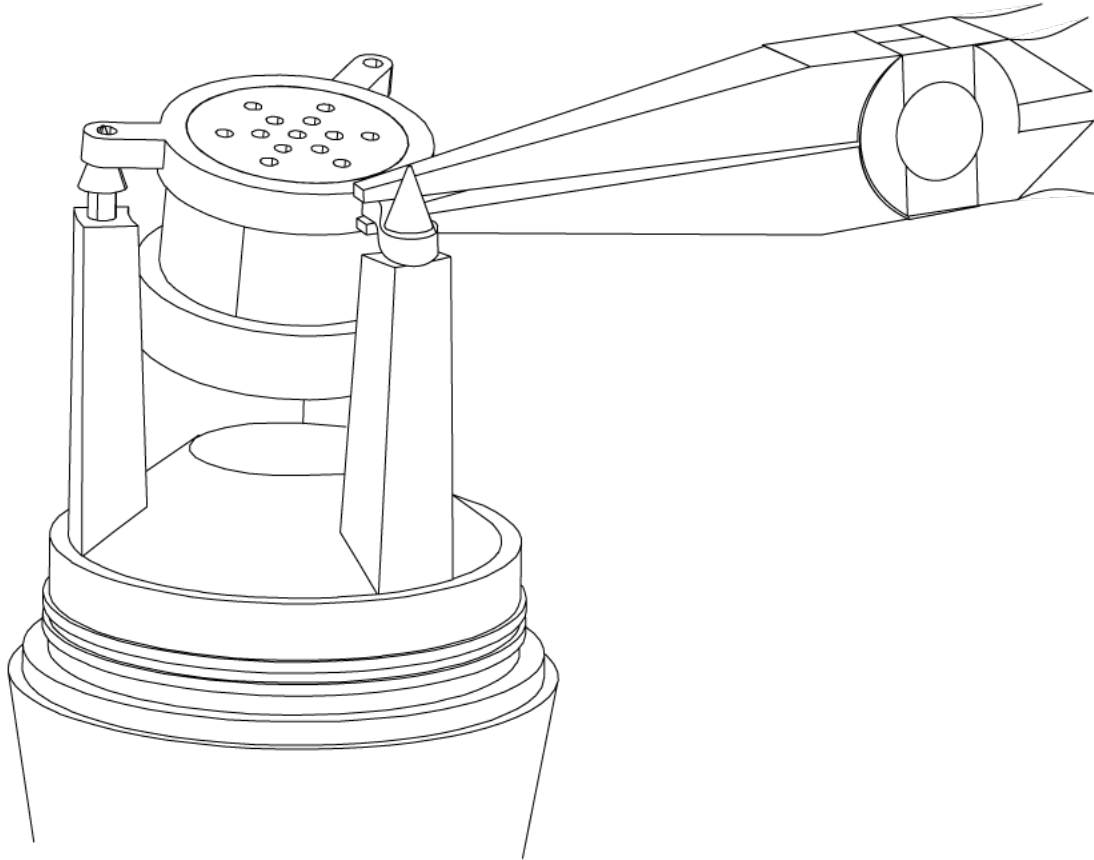

4. Attach the pins of the two leads to the sockets in the cartridge base. The green lead matches the center socket and the blue lead matches the outer socket
5. Install the new cartridge by slipping the rubber loops over the shock-mount posts.

Align the pin sockets as illustrated below.

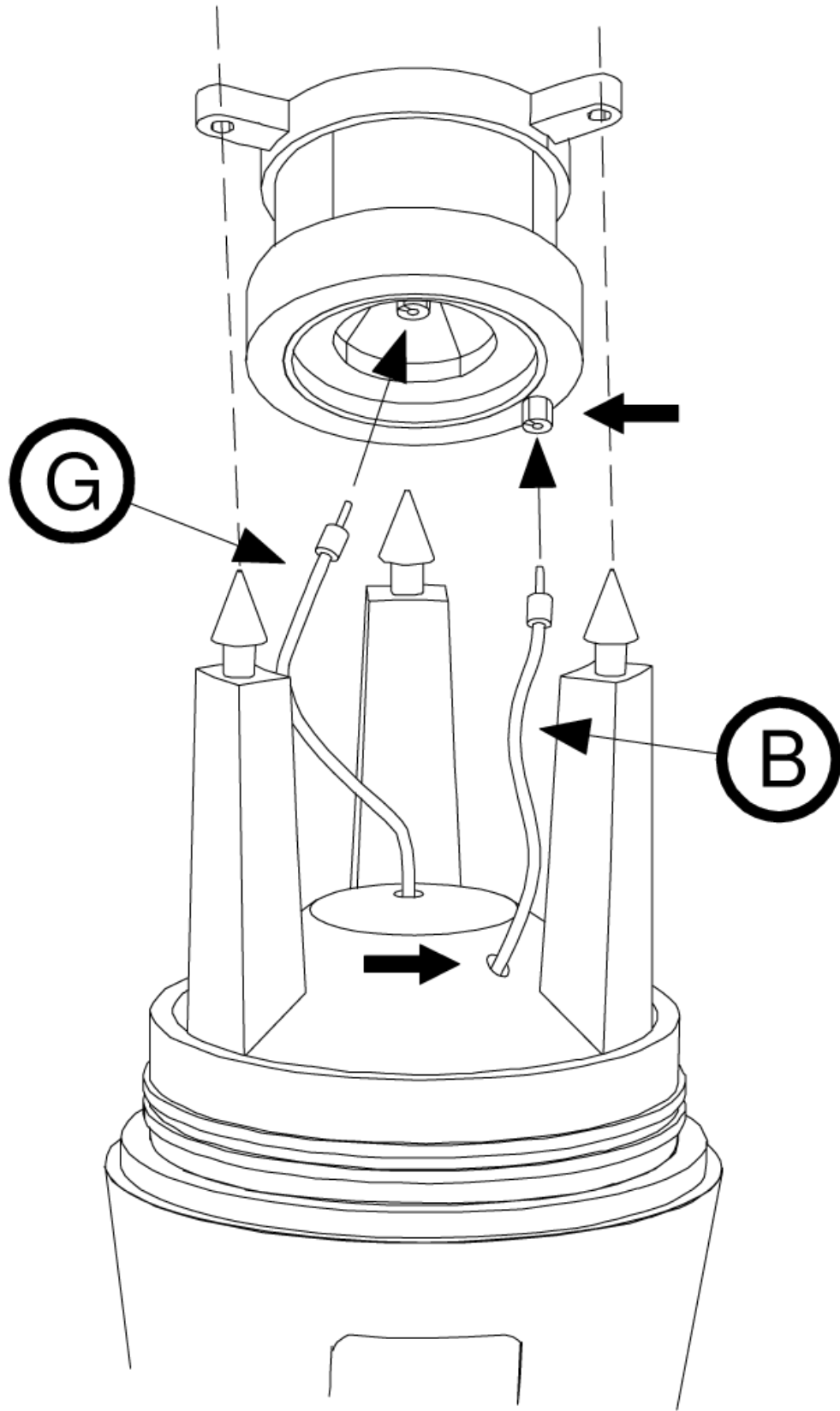

Once you have installed the cartridge, take care to position the blue end and green lead wires so they do not touch each other, the cartridge and any other part of the microphone. Otherwise, noise problems may occur.

Certifications

This product meets the Essential Requirements of all relevant European directives and is eligible for CE marking.

The CE Declaration of Conformity can be obtained from: www.shure.com/europe/compliance

Authorized European representative:

Shure Europe GmbH

Headquarters Europe, Middle East & Africa

Department: EMEA Approval

Jakob-Dieffenbacher-Str. 12

75031 Eppingen, Germany

Phone: +49-7262-92 49 0

Fax: +49-7262-92 49 11 4

Email: info@shure.de