

MODEL SM14A

HEAD-WORN MICROPHONE WITH RECEIVERS



GENERAL

The Shure Model SM14A Professional Head-Worn Microphone with Receivers is a low-impedance, unidirectional, dynamic microphone with two integral earphone assemblies. Each receiver assembly has its own transformer and phone plug for monitoring separate sound sources. Designed for sports and news announcing, interviewing and intercommunication systems, and for special-events remote broadcasting, the SM14A offers convenient, hands-free operation without user fatigue. A close-talking microphone, the SM14A may be used under noisy conditions without loss or masking of voice signals. The SM14A is a small, lightweight, rugged and reliable unit, with provisions for mounting to a supplied cushioned headband. A pivot housing permits the microphone boom to be moved 20° in any direction, and the distance between the microphone and pivot to be changed by up to 89 mm (3 ½ in.). The receiver ear tubes, attached to the bottoms of the pivot housings, may be moved through a 55° arc. A miniature windscreen to protect against wind noise and explosive breath sounds, and three connector belt clips are also supplied.

Model SM14A Features:

- Close-talk operation and unidirectional polar pattern for effective noise reduction
- Smooth natural voice frequency response
- Locking adjustment knob permits boom to pivot 20° in any direction
- Boom length adjustment through 89 mm (3 ½ in.) range
- Twin receivers monitor separate sound sources
- Receiver ear tubes adjustable through 55° arc
- Light weight plus padded headband eliminate user fatigue
- Does not interfere with eyeglasses
- Ruggedly constructed of stainless steel, aluminum and high-impact thermoplastic
- Convenient, secure clips attach connectors to belt or clothing

ASSEMBLY

Assemble the SM14A for use as follows:

1. Twist the lower headband arms 90° so they are perpendicular to the headband. For left side usage, the microphone retaining clip will be on the left side of the user's head; for right side usage, the microphone clip will be on the right (see photo and Figure 1).
2. Snap the microphone pivot housing into the retaining clip with the pivot adjustment knob upward and the microphone toward the front. Loosen the pivot adjustment knob, position the boom so that the microphone is near where the side of the mouth will be, and tighten the pivot adjustment knob.
3. Snap the pivot housing of the second receiver assembly into the remaining retaining clip with the receiver tip downward. Insert the receiver cable in the groove across the top of the headband. In this way, the two cables will be adjacent to each other.
4. Place the assembled microphone on the user's head and pull the headband arms downward until they rest against the head just over the ears. Position the receiver tips at the entrances to the ears. (Make certain cables are free of receiver ear tubes.)

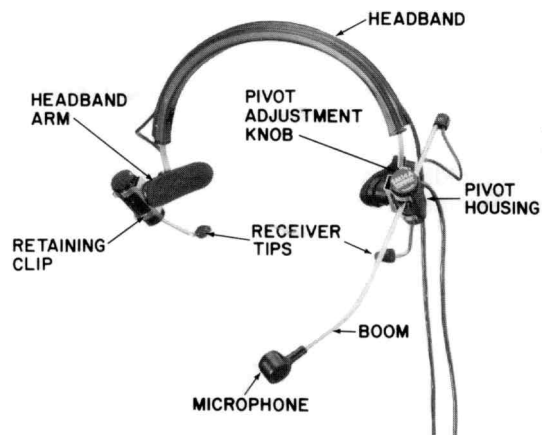

SM14A POSITIONED FOR LEFT SIDE OPERATION
FIGURE 1

SHURE®
 MODEL SM14A
 HEAD-WORN MICROPHONE WITH RECEIVERS

WARNING

Sustained high volume levels in conjunction with a tightly fitting receiver tip may adversely affect the user's hearing. Make certain the volume is set to a comfortable listening level and position the receiver tip at the entrance of the ear.

- Loosen the pivot adjustment knob and position the microphone as close as possible to the corner of the mouth. For optimum close-talking operation, the microphone should be less than 25 mm (1 in.) from the corner of the mouth. Be sure to position the microphone at the corner (not the center) of the mouth to eliminate explosive breath sounds ("pop"). Tighten the adjustment knob.
- Snap the microphone connector belt clip over the groove in the 3-pin audio connector and the receiver connector belt clips over the grooves in the phone plugs. The clips can now be fastened to the user's belt or other clothing. Attach the 3-pin audio connector to the microphone cable and the phone plugs to the monitoring unit cables.
- NOTE: A decrease in receiver output may be due to clogging of the receiver tip. The tip may be cleaned by removing it from the ear tube and inserting a toothpick or similar device through the tip hole. If clogging is apparent in the ear tube, carefully remove the obstruction from the ear tube tip. **CAUTION:** Do not disturb the foam damping material located just inside the ear tube tip.

SPECIFICATIONS

MICROPHONE

Type

Dynamic, Close-Talking

Frequency Response (at 8 mm [5/16 in.])

50 to 15,000 Hz (see Figure 2)

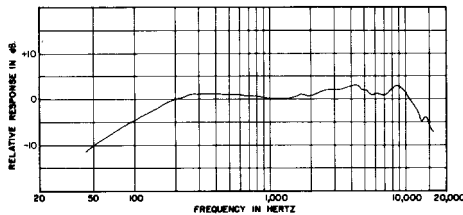

TYPICAL MICROPHONE FREQUENCY RESPONSE

FIGURE 2

Polar Pattern

Cardioid (unidirectional) response—uniform with frequency, symmetrical about axis (see Figure 3)

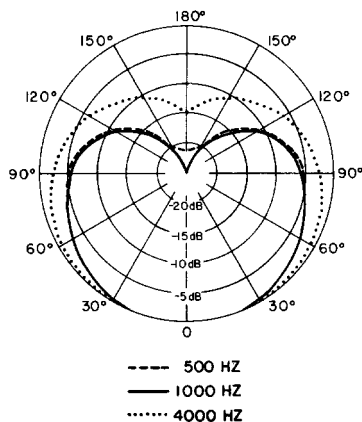

TYPICAL POLAR PATTERN

FIGURE 3

Impedance

Microphone rating impedance is 150 ohms (200 ohms actual) for connection to microphone inputs rated at 19 to 300 ohms

Output Level (close-talked at 1,000 Hz)

Open Circuit Voltage -47.0 dB (4.5 mV)
(0 dB = 1 volt per 100 microbars)

Power Level -66.0 dB
(0 dB = 1 milliwatt per 10 microbars)

Hum Sensitivity (typical)

38.4 dB equivalent SPL in a 1 millioersted field

Phasing

Positive pressure on diaphragm produces positive voltage on pin 2 of microphone connector

Connector

Professional three-pin audio connector designed to mate with Cannon XL series, Switchcraft A3 (Q.G.) series or equivalent connectors.

RECEIVERS

Type

Dynamic

Frequency Response

70 to 12,000 Hz

Impedance

2,000 ohms at 1 kHz (200-ohm cartridges with matching transformers in phone plugs)

Output Level

105 dB SPL with 1.4V at 1 kHz (1.0 mW into 2 cc cavity)

Phasing

Positive voltage on phone plug tips produces positive pressure in ear tubes

Connector

Phone plugs (contain matching 200:2,000 ohm transformers)

GENERAL

Cable

Non-detachable, 1.5m (5 ft), four-conductor, shielded, plastic-jacketed; 762 mm (2.5 ft), two-conductor receiver cable attached to microphone connector. Non-detachable, 2.9m (9.5 ft), two-conductor cable attached to second receiver assembly.

Case

Black thermoplastic microphone and pivot housings, anodized aluminum end caps, stainless steel grille, ear tubes and boom

Dimensions

See Figure 4

Net Weight

103 grams (3½ ounces) less cables and connectors

Packaged Weight

890 grams (1 lb, 15 oz)

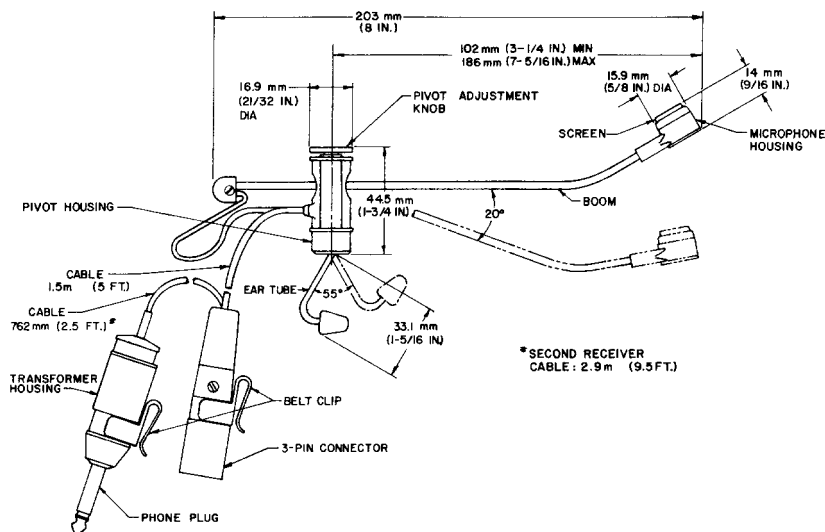

OVERALL DIMENSIONS
FIGURE 4

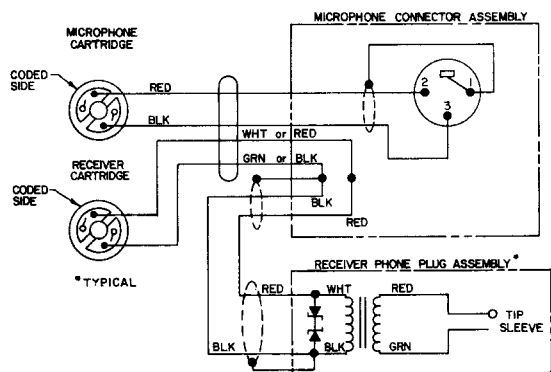

INTERNAL CONNECTIONS
FIGURE 5

ARCHITECTS' SPECIFICATIONS

The microphone with receivers shall be the Shure Model SM14A or equivalent. The microphone shall be a moving-coil (dynamic) type with a frequency response of 50 to 15,000 Hz. The unit shall have a cardioid polar characteristic. The cancellation at the rear shall be 15 to 20 dB. The microphone shall be low impedance with a rated impedance of 150 ohms for connection to microphone inputs rated at 19 to 300 ohms.

The microphone output shall be -66.0 dB where 0 dB = 1 milliwatt per 10 microbars.

The receivers shall be dynamic types with a frequency response of 70 to 12,000 Hz. The receivers shall be supplied with integral connector-mounted matching transformers designed with an impedance of 2,000 ohms.

The microphone with receivers shall be a head-worn type, and shall be provided with a 1.5m (5 ft), non-detachable, four-conductor (two-conductor shielded) microphone cable with a professional three-pin audio connector designed to mate with Cannon XL series, Switchcraft A3 (Q.G.) series or equivalent connectors. An additional 762 mm (2.5 ft) cable length shall be provided between microphone and one receiver (phone plug) connectors. The second receiver shall have its

own 2.9 m (9.5 ft) cable. The microphone shall also be provided with a headband, three connector belt clips, and a foam windscreen.

The overall dimensions of the microphone shall be 203 mm (8 in.) in length and 44.5 mm (1-3/4 in.) in maximum height (pivot housing). The microphone housing shall be 15.9 mm (5/8 in.) in diameter and 14 mm (9/16 in.) in height.

ACCESSORIES AND REPLACEMENT PARTS

The following furnished accessories and replacement parts may be ordered through your Authorized Shure Professional Products Dealer or from Shure Brothers Inc.

Connector Belt Clip	RK200BC
Windscreen	RK184WS
Carrying Case	90A2255
Microphone Cartridge	R93
Receiver Cartridge	R94
Headband Assembly	90B3605
Receiver Tip	RK190

GUARANTEE

This Shure product is guaranteed in normal use to be free from electrical and mechanical defects for a period of one year from date of purchase. Please retain proof of purchase date. This guarantee includes all parts and labor. This guarantee is in lieu of any and all other guarantees or warranties, express or implied, and there shall be no recovery for any consequential or incidental damages.

SHIPPING INSTRUCTIONS

Carefully repack the unit, have it insured, and return it prepaid to:
Shure Brothers Incorporated
Attention: Service Department
222 Hartrey Avenue
Evanston, Illinois 60204

If outside the United States, return the unit to your dealer or Authorized Shure Service Center for repair. The unit will be returned to you prepaid.