

SHURE®

GENERAL

The Shure Model SM85 is a professional-quality, hand-held, unidirectional condenser microphone designed for the most demanding applications in sound reinforcement, broadcasting and studio recording. It is especially suitable for applications requiring wide frequency response, low distortion characteristics, very low RF susceptibility, and reliable operation over a wide range of temperature and humidity extremes. The SM85 makes optimum use of proximity effect to give the performer control of low-frequency sound, from the warm intimacy of close miking to the natural sounds of normal-to-distant miking. The SM85 also features an integral wind and pop filter, a high-frequency presence peak, a controlled low-frequency rolloff, and an effective shock mount for reduced stand and handling noise. The case is constructed of aluminum for light weight and ruggedness, with a steel grille and durable black finish.

The SM85 is designed for simplex (phantom) powering from an external supply or directly from sound reinforcement, broadcast, or recording equipment. The SM85 operates over an extremely wide voltage range of 11 to 52 Vdc, covering both DIN Standard 45 596 simplex voltages of 12 and 48 volts, and the proposed 24-volt standard.

The microphone is supplied with an accessory swivel adapter. Model SM85-LC is supplied without a cable, and Model SM85-CN is supplied with a 7.6m (25 ft) TRIPLE-FLEX® microphone cable with professional audio connectors. Two dual-channel power supplies (Models PS1 and PS1E2) are available for providing simplex power to the SM85.

Model SM85 Features:

- Wide-range frequency response tailored for professional vocal applications
- Built-in wind and pop filter minimizes undesirable wind and breath sounds
- Controlled low-frequency rolloff to reduce low-frequency handling noise and compensate for proximity effect
- Transducer element shock-mounted for reduced stand and handling noise
- Low distortion output and wide dynamic range characteristics for a variety of load impedances
- Cardioid polar pattern, uniform with frequency and symmetrical about axis, to provide maximum rejection and minimum coloration of off-axis sounds
- Very low RF and magnetic hum susceptibility
- Wide-range simplex powering includes DIN 45 596 voltages of 12 and 48 Vdc
- Rugged construction for outstanding reliability
- Field-usable over wide range of temperature and humidity conditions



SPECIFICATIONS

Type

Cardioid condenser (electret bias)

Frequency Response

50 to 15,000 Hz (see Figure 1)

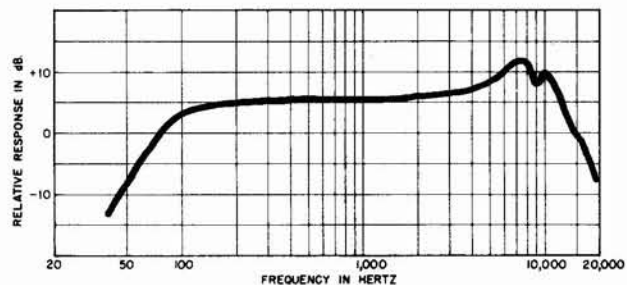

TYPICAL FREQUENCY RESPONSE

FIGURE 1

Polar Pattern

Cardioid (unidirectional) response — uniform with frequency, symmetrical about axis (see Figure 2)

Output Impedance

Rated at 150 ohms (85 ohms actual)

Recommended minimum load impedance: 800 ohms
(May be used with loads as low as 150 ohms with reduced clipping level)

Output Level (at 1,000 Hz)

Open Circuit Voltage - 74 dB (0.2 mV)
(0 dB = 1 volt per microbar)

Clipping Level (at 1,000 Hz)

800-ohm Load - 4 dBV (0.63V)
150-ohm Load - 15 dBV (0.18V)

UNIDIRECTIONAL CONDENSER MICROPHONE

MODEL SM85



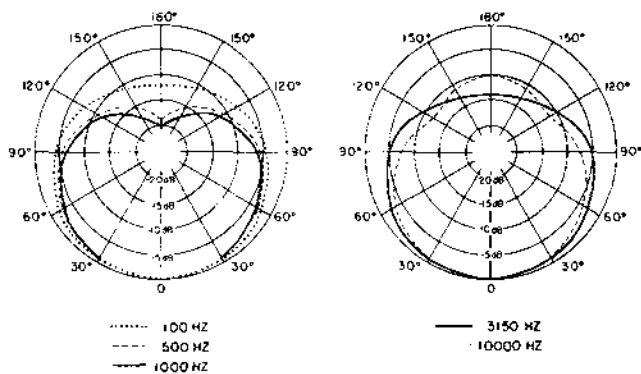

TYPICAL POLAR PATTERNS
FIGURE 2

Total Harmonic Distortion

Less than 0.25% (130 dB SPL at 250 Hz into 800-ohm load)

Maximum SPL

142 dB with 800-ohm load
134 dB with 150-ohm load

Hum Pickup

- 7.5 dB equivalent SPL in a 1 millioersted field (60 Hz)

Output Noise (equivalent sound pressure levels; measured with true rms voltmeter)

29 dB typical, A-weighted
32 dB typical, weighted per DIN 45 405

Dynamic Range

113 dB (maximum SPL to A-weighted noise level)

Signal-to-Noise Ratio

65 dB (IEC 179)* at 94 dB SPL

Overvoltage and Reverse Polarity Protection

Max. External Voltage Applied to
Pin 2 and 3 with Respect to Pin 1 + 52 Vdc
Reverse Polarity Protection 200 mA max.
(diode-clamped)

Phasing

Positive pressure on diaphragm produces positive voltage on pin 2 relative to pin 3

Cartridge Capacitance

27 pF

Power

Supply Voltage ... 11 to 52 Vdc, positive pins 2 and 3
Current Drain 1.0 mA to 1.2 mA

Environmental Conditions

Relative Humidity 0 - 50% -29° to 74°C
(-20° to 165°F)
Relative Humidity 0 - 95% -29° to 57°C
(-20° to 135°F)

Connector

Three-pin professional audio**

Case

Aluminum construction with black finish and black steel grille

Dimensions

See Figure 3

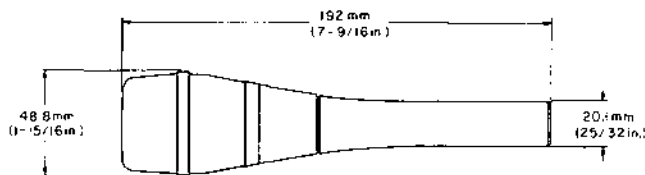

OVERALL DIMENSIONS
FIGURE 3

Weight

Net 180 grams (6.3 oz)
Packaged SM85-LC: 887 grams (1 lb 15 oz)
SM85-CN: 1.47 kilograms (3 lb 4 oz)

Cable (Model SM85-CN)

7.6m (25 ft), two-conductor, shielded, TRIPLE-FLEX® with three-pin and three-socket professional audio connectors (microphone connector is black finish)**

OPERATION

The SM85 is designed for simplex powering by a Shure Model PS1 or PS1E2 Power Supply, or by virtually any microphone power supply providing 12 to 48 Vdc simplex voltage, or by any microphone mixer (such as the Shure M267 and M268) with a simplex supply.

Use only high-quality cables, as intermittent shorts between broken shield wires and balanced conductors will cause objectionable noise transients in the system. Paralleling or "Y-ing" the SM85 with another microphone (two microphones on the same input) is not recommended; separate inputs are preferable. However, paralleling two SM85's may be accomplished with either a reduction in maximum SPL and output level, or a reduction only in output level if the microphones are electrically isolated. With the microphones paralleled either before or after a PS1 or PS1E2 Power Supply, the maximum SPL is reduced by approximately 10 dB and the output level by 6 dB. The reduction in maximum SPL can be avoided by using either two Shure A15AS Attenuators and a Switchcraft 391Q43 Y-Adapter to isolate the microphones, or an isolation network as shown in Figure 4. The network reduces each microphone output level by 8 dB, while the A15AS reduces the output level by 5 dB plus the attenuator's 15, 20, or 25 dB (switch-selectable). The network or attenuators can be inserted between the power supply outputs and mixer input. Note that a PS1 or PS1E2 Power Supply can power two SM85's on each input; other power supplies should be checked to see if they can supply a minimum of 11 Vdc at each microphone when both microphones are connected.

A minimum load impedance of 800 ohms or greater should be used for maximum signal handling and minimum distortion. The load may be as low as 150 ohms, but a reduction in output clipping level will result. It should be noted that the power supply itself may add loading (3300 ohms in the Shure PS1 or PS1E2 power supplies) to the microphone.

PS1 and PS1E2 POWER SUPPLIES

Connect the microphone cable to the SM85 and the power supply MICROPHONE connector. The power supply uses the balanced audio cable pair to carry the supply current to the microphone, and the cable shield as a ground return.

*S/N ratio is difference between microphone output at 94 dB SPL and microphone self-noise A-weighted.

**Designed to mate with Cannon XL series, Switchcraft A3 (Q.G.) series or equivalent connectors.

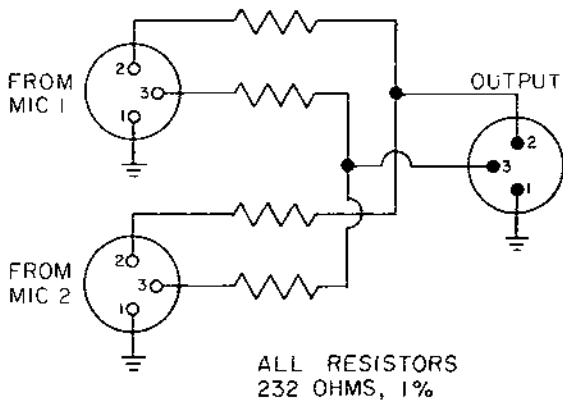

ISOLATION NETWORK
FIGURE 4

Connect the power supply OUTPUT connector to a low-impedance microphone input of a mixer, audio console or tape recorder. A second SM85 may be connected to the remaining power supply channel in a similar manner.

ALTERNATE POWER SOURCES

As an alternate to the PS1 or PS1E2 power supplies, the SM85 can be simplex-powered from virtually any mixer, audio console or tape recorder using one of the wiring configurations shown in Figures 5 and 6. Any well-filtered voltage available in the mixer from 12 to 48 Vdc may be used. The graph in Figure 7 shows the range of values which can be used for resistor R when the SM85 is used with a regulated power supply. The tolerance of the resistors (2R) shown in Figure 5 should be 1% or better to assure close matching, although the absolute value is not critical. Note that the two-resistor simplex power supply (Figure 5) presents a load equal to 4R, paralleled with the mixer input impedance, to the SM85. If the combined parallel load is below 800 ohms, the transformer configuration (Figure 6) is recommended, and if the combined load is 150 ohms or less, it must be used.

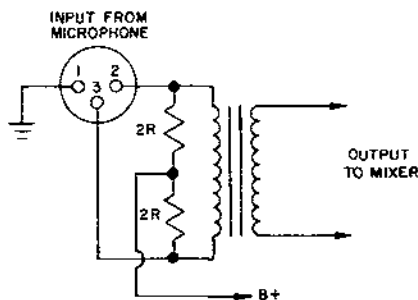

TWO-RESISTOR CONFIGURATION
FIGURE 5

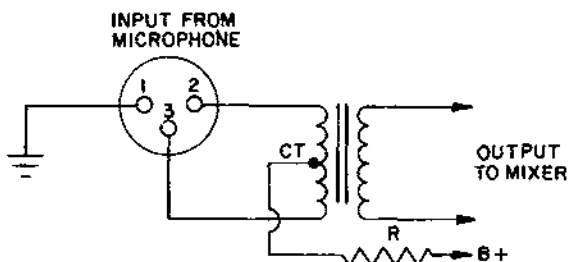

CENTER-TAPPED TRANSFORMER
CONFIGURATION
FIGURE 6

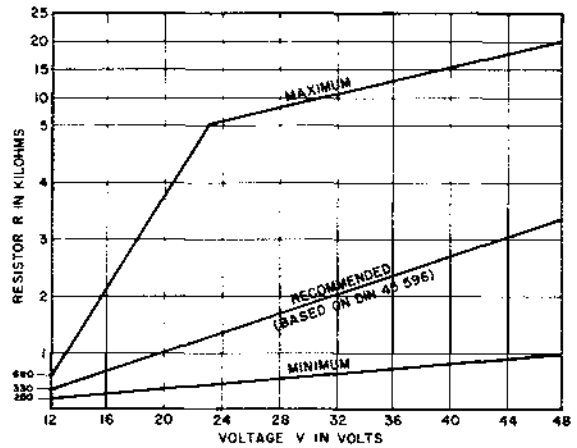

RESISTOR R VALUES
FIGURE 7

If the power supply is unregulated, the power supply voltage may drop when the SM85 is connected to it, due to the added load. To account for this load, the value of R may be determined as follows. Connect a variable resistance (or resistor substitution box) in series with a 10-kilohm, 10% resistor. Connect the free end of the 10k resistor to ground and the free end of the variable resistor to B+ of the power supply. Adjust the variable resistor until 12 to 36 volts is measured across the 10k resistor. Note the actual dc supply voltage and the value of the variable resistor. Verify that the resistor value falls within the indicated range on the graph of Figure 7. The value of the variable resistor is the appropriate resistance R for use in Figure 6. If the configuration in Figure 5 is to be used, double the resistor value (2R). Voltages as low as 10 Vdc minimum as measured at the microphone connector are acceptable. The nominal current drain at 10 Vdc is 1.1 mA. This is the minimum current a power supply must be able to deliver for proper operation.

For example, in mixers with 30 Vdc power supplies, the value of 2R for the configuration in Figure 4 could be 3.6k. Two 3.6k resistors should be closely matched (2% or better), and may be mounted externally with the B+ end connected to the 30V terminal. The resistors may also be mounted internally (such modifications should be performed by qualified service personnel only).

A convenient method of battery-powering the SM85 using two 9-volt batteries is shown in Figure 8. Note

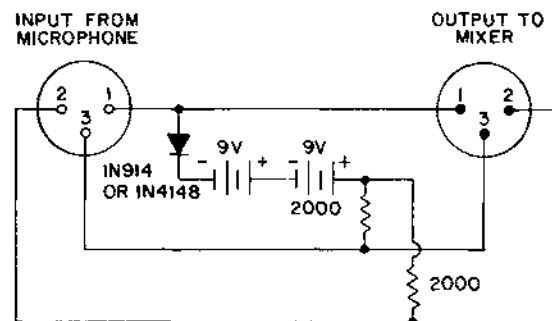

BATTERY POWER SUPPLY
FIGURE 8

that this circuit can only be used with balanced, floating (ungrounded), transformer-coupled input mixers such as the Shure M67 or SE30. The resistors should be 1% tolerance or better to assure close matching. With new batteries, this supply will operate an SM85 for approximately 200 hours.

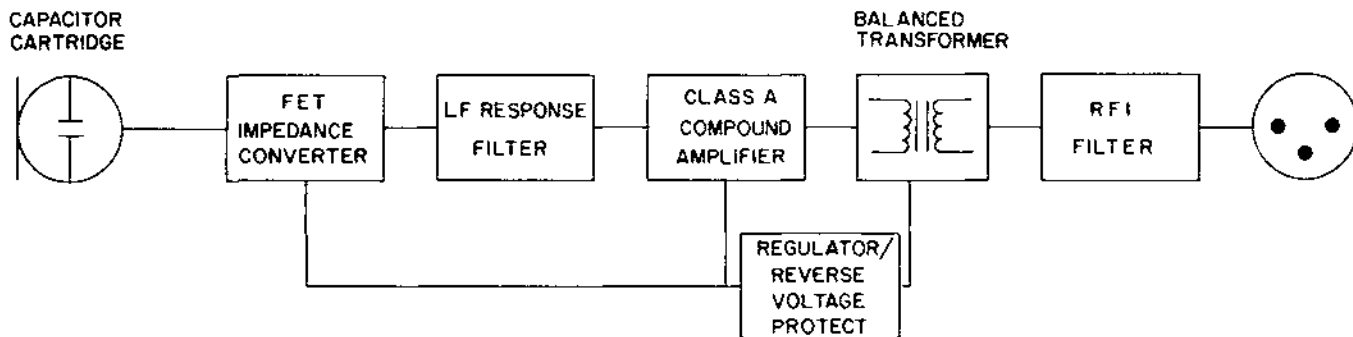

BLOCK DIAGRAM
FIGURE 9

WIND NOISE

The SM85 has an integral wind and pop filter which provides excellent protection against most wind and breath noise. Under adverse conditions, such as a windy day outdoors, or close proximity to a "problem" vocalist, the optional foam windscreen can be used.

CIRCUIT DESCRIPTION

A block diagram of the SM85 is shown in Figure 9. The capacitor cartridge is followed by a field-effect transistor (FET) impedance conversion stage. The FET output drives an active low-frequency rolloff (high-pass) filter. The filter output from the compound transistor, Class A, emitter-follower amplifier is transformer-coupled, providing a balanced output to the RFI protection filter at the microphone connector. An active constant-current, power supply circuit regulates the simplex voltage, allowing the SM85 to operate over a very wide range of voltages. A reverse voltage protection diode guards against miswired cables and equipment. The circuit contains five semiconductors to provide low noise, low distortion, wide frequency response, and ultra-reliable operation over a very wide range of operating conditions.

SERVICING

TROUBLESHOOTING

Due to the high packing density and circuit complexity of the SM85, only basic servicing is recommended. The following steps should be taken if problems arise.

1. Check the power supply output voltage to the microphone. For the Shure PS1 or PS1E2, this should be 21.5 ± 1.5 Vdc open circuit.
2. Check the voltage on microphone connector pins 2 and 3 (at back of connector; cable connector disassembled from shell but connected to microphone). The voltage at pins 2 and 3 with reference to pin 1 should be between 10 and 48 Vdc.

DISASSEMBLY

See Figure 10.

ARCHITECTS' SPECIFICATIONS

The microphone shall be a condenser microphone with a frequency response of 50 to 15,000 Hz. It shall have a cardioid directional characteristic, with cancellation at the sides of 6 dB and a minimum cancellation at the rear of 15 dB at 1 kHz. The microphone shall have a rated output impedance of 150 ohms for connection to microphone inputs of 150 ohms or higher. The open circuit voltage shall be -74 dB (0.2 mV) (0 dB equals 1 volt per microbar).

The overall dimensions shall be 192 mm (7-9/16 in.) in length by 48.8 mm (1-15/16 in.) in diameter. The handle diameter shall be 20.1 mm (25/32 in.). The weight shall be 180 grams (6.3 oz).

The microphone shall be capable of being powered by a simplex (phantom) power supply with an output of 11 to 52 Vdc, or by a mixer, audio console or tape recorder capable of supplying 11 to 52 Vdc.

The microphone shall be a Shure Model SM85.

FURNISHED ACCESSORY

Swivel Adapter A57E

OPTIONAL ACCESSORIES

Simplex Power Supply PS1, PS1E2
Switch-Selectable Attenuator A15AS
Isolation Mount A53M
Windscreen A85WS

REPLACEMENT PARTS

Screen and Grille RK214G
Cartridge and Shock Mount R112
Amplifier 90A3024
Case* 90A3029
RFI Filter and Plug Element 90A3622
Cable (SM85-CN only) C25E

*Includes RFI Filter and Plug Element.

GUARANTEE

This Shure product is guaranteed in normal use to be free from electrical and mechanical defects for a period of one year from date of purchase. Please retain proof of purchase date. This guarantee includes all parts and labor. This guarantee is in lieu of any and all other guarantees or warranties, express or implied, and there shall be no recovery for any consequential or incidental damages.

SHIPPING INSTRUCTIONS

Carefully repack the unit, have it insured, and return it prepaid to:

Shure Brothers Incorporated
Attention: Service Department
222 Hartrey Avenue
Evanston, Illinois 60204

If outside the United States, return the unit to your dealer or Authorized Shure Service Center for repair. The unit will be returned to you prepaid.

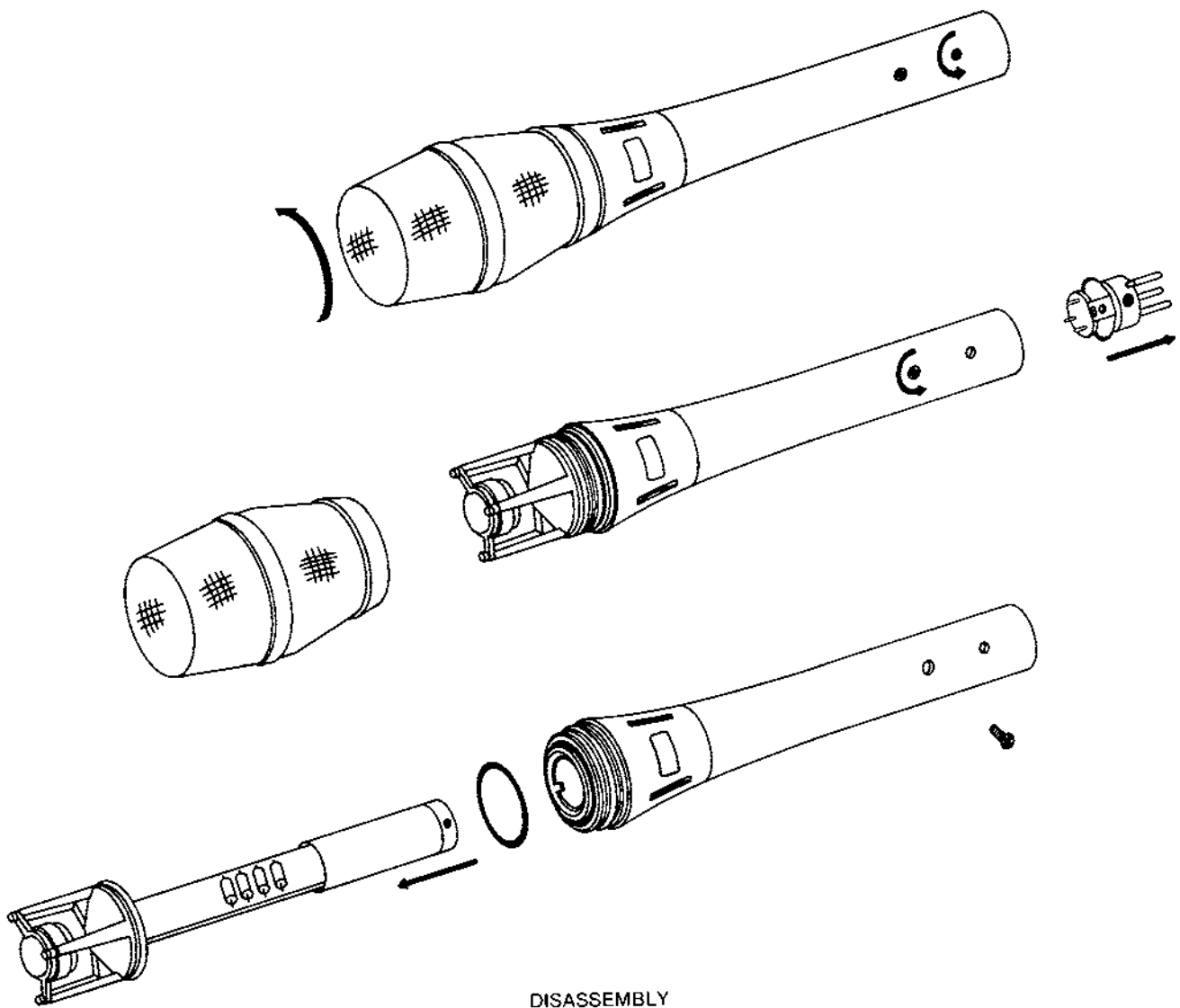

DISASSEMBLY
FIGURE 10

SHURE[®]
SOUND OF THE PROFESSIONALS[®]