

SHURE®

THE SOUND OF THE PROFESSIONALS®

222 HARTREY AVE., EVANSTON, IL 60202-3696 U.S.A.
AREA CODE (312)866-2200 • CABLE: SHUREMICRO
TELEX: 4330191 • FAX (312)866-2279

PROFESSIONAL PRODUCTS

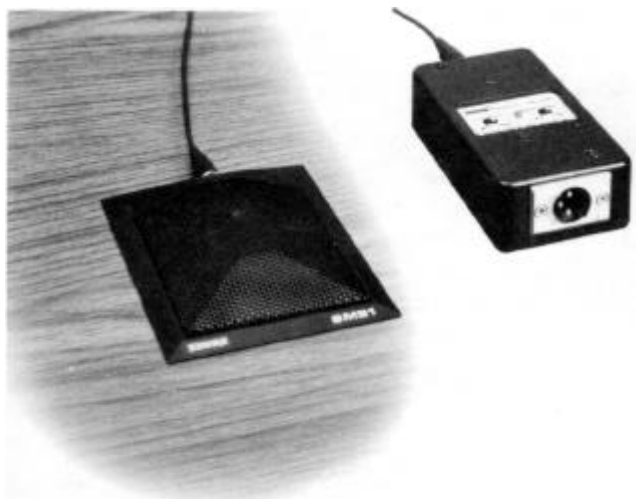

GENERAL

The SM91 Microphone is designed specifically for surface-mounted applications. It is a professional-quality permanently-biased condenser microphone with a half-cardioid directional pattern (cardioid in the hemisphere above the mounting surface.)

The SM91 takes advantage of the well-known principle that, at a barrier or boundary, sound pressure doubles compared to its value if the boundary is removed. When placed sufficiently near the boundary surface, a microphone has effectively 6 dB higher sensitivity and approximately 3 dB greater rejection of random background noise.

Because of its half-cardioid polar pattern, the SM91 surface-mounted microphone discriminates against sounds originating from the rear, suiting the SM91 for conditions where an omnidirectional pattern makes other surface-mounted microphones impractical. The intrinsic unidirectionality of the SM91 can be a great benefit when it is desirable to isolate a particular vocalist, instrument, or group from the rest of an ensemble being recorded. Because of a cardioid pickup pattern, no physically isolating barriers are required, and directionality is maintained to low frequencies.

The SM91 can be used for individual instrument pickup, e.g., mounted inside the lid of a grand piano or on the floor next to a bass drum. Experimental placement and critical listening will demonstrate the best location for any particular purpose or effect desired.

The meticulously optimized design of the SM91 includes a totally new cartridge, developed at Shure. The result is high output, notably accurate sound reproduction over the entire audio frequency range, and off-axis performance comparable to the finest unidirectional microphones. The supplied low-distortion, high-

clipping-level preamplifier provides switch-selectable Flat or Low-Cut response for further assistance in obtaining the best possible microphone signal even under difficult conditions.

The SM91 is powered either by two readily available 9-volt alkaline batteries (300 hours continuous battery life) or by an 11-to-52 Vdc simplex (phantom) supply from broadcast, sound-reinforcement, or recording equipment. The system is designed so that the battery supply will automatically switch in should the simplex power fail.

The SM91 consists of a small, rugged, surface-mounted microphone finished in professional durable matte-black enamel; a 7.6m (25 ft) small diameter two-conductor shielded interconnecting cable with two 3-socket miniature Switchcraft connectors; and a sturdy preamplifier assembly with battery compartment, battery On/Off switch, green LED battery-condition indicator, low-frequency Flat/Lo Cut switch, and standard 3-pin professional audio connector output.

Features:

- Wide flat frequency response for accurate sound reproduction across the audio spectrum
- Switch-selectable 12 dB/octave low-frequency cutoff permits tailoring response to suit conditions
- Half-cardioid polar pattern minimizes pickup from rear of microphone, permits aiming microphone, e.g., toward performers and away from audience, or toward singers and away from instruments
- High sensitivity and high signal-to-noise-ratio
- Very low distortion and high output clipping level
- Battery or simplex powering: uses standard 9-volt alkaline batteries; accepts wide range of simplex voltages - 11 to 52 Vdc
- Low susceptibility to RFI, electrostatic and electromagnetic hum
- Extremely rugged construction of both microphone and preamplifier for outstanding reliability
- Low profile and matte black finish for unobtrusive appearance on-camera or onstage; on floor, table, ceiling, wall, or lectern
- Usable over very wide range of temperature and humidity

SHURE®
MODEL SM91 • SURFACE - MOUNTED UNIDIRECTIONAL CONDENSER MICROPHONE
TECHNICAL DATA

SPECIFICATIONS

Type

Cardioid condenser (electret bias) for surface mounting

Frequency Response

20 to 20,000 Hz at 30° incidence to infinite surface (see Figure 1)

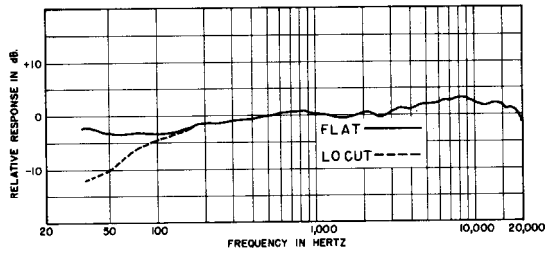

TYPICAL FREQUENCY RESPONSE

FIGURE 1

Polar Pattern

Half-cardioid (cardioid in hemisphere above mounting surface), uniform with frequency, symmetrical about axis (see Figure 2)

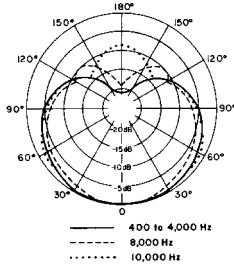

TYPICAL POLAR PATTERN

FIGURE 2

Output Impedance

Rated at 150 ohms (90 ohms actual)
Recommended minimum load impedance: 800 ohms
(May be used with loads as low as 150 ohms with reduced clipping level)

Output Level (at 1,000 Hz, measured with sound source at 30° incidence to infinite surface)

Open Circuit Voltage -71.5 dB (0.27 mV)
0 dB = 1 V/ μ bar

Preamplifier Output Clipping Level (at 1,000 Hz, less than 0.1% THD)

800 ohm load 0 dBV (1.0V)
150 ohm load -13 dBV (0.22V)

Maximum SPL (at 1,000 Hz, sound source at 30° incidence to infinite surface)

800 ohm load 146.5 dB
150 ohm load 136.5 dB

Hum Pickup

-13.5 dB equivalent SPL in 1 mOe field (60 Hz)

Output Noise

25.5 dB SPL, A-weighted
28.5 dB SPL, weighted per DIN 45 405

Signal-to-Noise Ratio

68.5 dB re 94 dB SPL

Dynamic Range

121 dB

Phasing

Positive pressure on diaphragm produces positive voltage on pin 2 relative to pin 3 of preamplifier output connector.

Power

Battery: Two 9-Vdc alkaline (NEDA 1604A), approximately 300 hours continuous with fresh alkaline batteries

Simplex Voltage: 11 to 52 Vdc, operational down to 9 Vdc; 1.8 mA current drain; permissible to use simplex power with batteries in place or removed

Switches and Indicator

Two recessed slide switches and green LED indicator on top surface of preamplifier assembly

Battery On/Off Switch: Move to On to power from batteries or to use batteries as backup power in case of interruption to external power supply (no battery drain occurs as long as simplex voltage source is greater than battery voltage). Move to Off to prevent battery drain when unit is not in use.

LED Indicator: Green LED flashes momentarily when switch is moved to On to indicate at least 8 hours of battery life remaining.

Flat/Lo Cut Switch: In Flat position, 6 dB/octave rolloff below 30 Hz; In Lo Cut position, 12 dB/octave rolloff below 80 Hz (see Figure 1)

Cable

7.6m (25 ft) two-conductor shielded, small diameter, interconnecting cable with 3-socket miniature Switchcraft connector on each end to mate with microphone output connector and preamplifier input connector

Case

Microphone: Matte black enamel die-cast base and perforated steel grille with replaceable or cleanable fine mesh screen and foam pad wind/dirt barrier

Preamplifier: Matte black enamel die-casting

Dimensions

See Figure 3

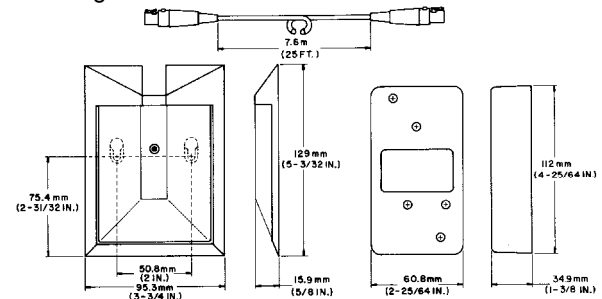

OVERALL DIMENSIONS

FIGURE 3

Environmental Conditions

Operating Temperature: -18° to 57°C (0° to 135°F)
Storage Temperature: -29° to 74°C (-20° to 168°F)
Relative Humidity (Operating or Storage): 0 to 95%

Net Weight

Microphone: 263 grams (9.3 oz) less cable
Preamplifier: 435 grams (15.4 oz) less batteries

LOCATION

To maintain the flattest possible low-frequency response and the best rejection of random background noise, choose a flat surface as large as possible on which to locate the SM91. The surface can be a floor, wall, ceiling or table.

A small mounting surface causes a low-frequency rolloff beginning at the frequency whose wavelength is comparable to the size of the surface. The rolloff continues at a rate of about 3 dB per octave until it reaches a plateau approximately 6 dB lower than the mid- and high-frequency response. In a similar fashion, a small mounting surface decreases the rejection of low-frequency background noise.

MOUNTING

The SM91 Microphone can be permanently mounted to a lectern, tabletop, floor, ceiling, or wall using two No. 6 screws located 50.1 mm (2 in.) apart. The location of two keyhole slots in the base of the microphone is marked on the nameplate. Cut through the marked slots before sliding the base onto the screws.

To avoid ground loops and resultant hum, avoid grounding the microphone preamplifier housing to metal building structures.

POWERING THE SM91

The SM91 can be powered by two internal 9-volt alkaline batteries or by an external simplex supply of 11 to 52 volts dc.

To use batteries, move the Battery On/Off switch to On. The green LED will indicate at least 8 hours of battery life remaining by flashing once when the switch is moved to On. **If the LED does not flash, the batteries should be replaced.** A battery-powered SM91 preamplifier output can be connected to any balanced-line low-impedance input.

To use simplex power, connect the preamplifier output to a balanced-line microphone input supplying 11 to 52 Vdc simplex (phantom) power. The batteries may be left in place while the unit is externally powered. There will be no battery drain as long as the simplex voltage

exceeds the battery voltage with the battery switch On, or if the battery switch is turned Off.

BATTERY INSTALLATION

To install batteries, remove the four screws in the corners of the preamplifier case. Lift off the case cover and gasket exposing the battery compartment. The use of 9-volt alkaline batteries (NEMA 1604A or equivalent) is highly recommended. Two batteries are required; always replace batteries in pairs.

Remove the batteries if the unit will not be used for a long period of time.

INTERCONNECTING CABLE

One 7.6m (25 ft) cable is supplied for connecting the SM91 Microphone to its Preamplifier. To retain access to the switches located on the preamplifier, it is sometimes desirable for the units to be located a greater distance apart. Up to 15m (50 ft) of additional cable can be used between the SM91 Microphone and Preamplifier with no loss in response or output



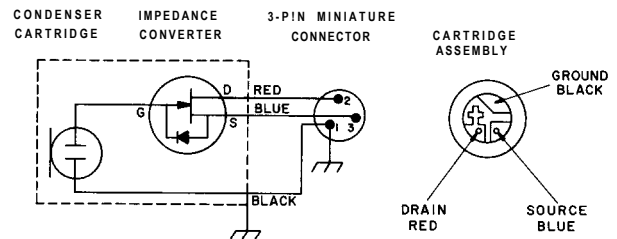

CLEANING

When the microphone is located in a dusty environment, periodic cleaning may be desirable. This can be easily accomplished by removing the Phillips-head screw on the grille, and lifting off the grille, the fine mesh screen, and the foam pad. Clean the fine stainless steel mesh screen by washing it in soapy water. Dry it thoroughly, and replace the foam pad, screen, and grille. Fasten firmly with the Phillips screw.

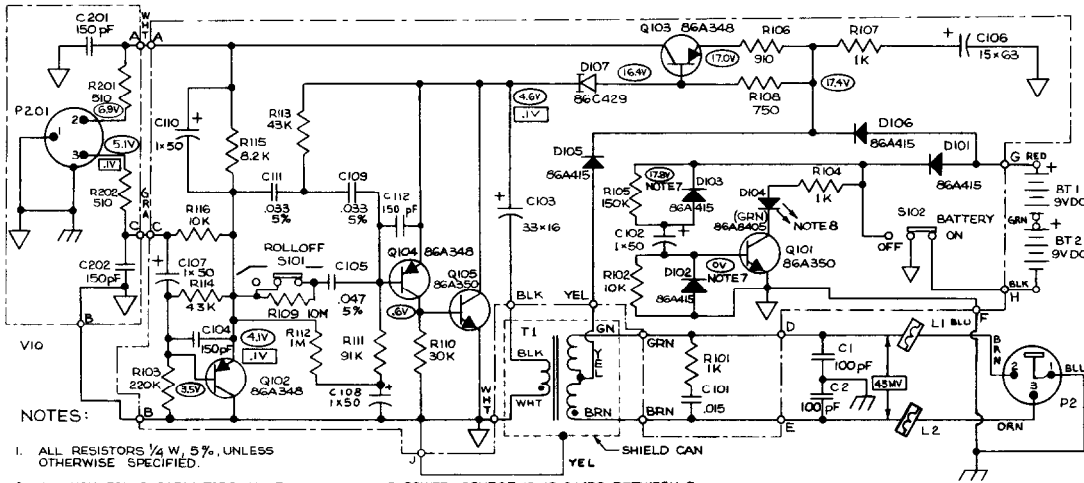

MICROPHONE CIRCUIT DIAGRAM
FIGURE 4



- NOTES:
1. ALL RESISTORS 1/4 W, 5%, UNLESS OTHERWISE SPECIFIED.
 2. ALL NON-POLAR CAPACITORS IN μ F, TOLERANCE 10% AND 50 VOLTS OR MORE UNLESS OTHERWISE SPECIFIED. POLARIZED CAPACITORS SHOWN IN μ F + VOLTS.
 3. FOLLOWING SYMBOLS DENOTE:
 CASE GROUND
 CIRCUIT BOARD GROUND
 D.C. VOLTAGE
 A.C. VOLTAGE
 4. INPUT SIGNAL OF 0.1V AT 1KHZ APPLIED TO PIN 3 OF P1 THROUGH 150 Ω .
 5. D.C. VOLTAGES MEASURED WITH 11 MEG. INPUT VOLTMETER; A.C. VOLTAGES MEASURED WITH 1 MEG. INPUT VOLTMETER. VALUES SHOWN ARE TYPICAL AND MAY VARY \pm 20%.

PREAMPLIFIER CIRCUIT DIAGRAM
FIGURE 5

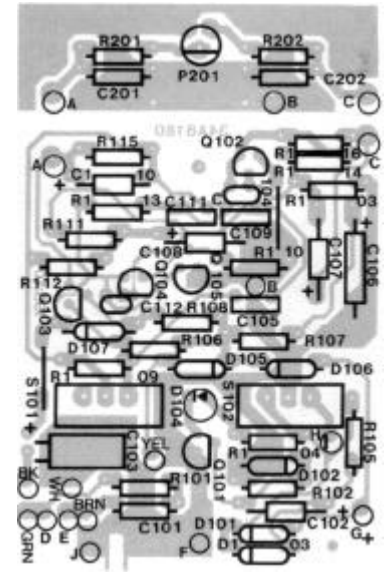

PREAMPLIFIER PC BOARD
FIGURE 6

REPLACEMENT PARTS LIST

Reference Designation	Part Number	Description	Commercial Alternate
A1	90A8216	Printed Circuit Board Assembly	None
A2	R129	Microphone Cartridge & impedance Converter	None
C102, 107, 108, 110	86S628R	Capacitor, Electrolytic, 1 μ F, 50 Wvdc	None
C103	86AE629	Capacitor, Electrolytic, 33 μ F, 16 Wvdc	Mallory VTL33S25
C106	86W628R	Capacitor, Electrolytic, 15 μ F, 63 Wvdc	None
D101, 102, 103, 105, 106	86A415R	Diode, Computer, 75V, 0.4A	TI, GE 1N4148
D104	86A8405	LED, Green	None
D107	86C429	Diode, Current Regulator, 1.3 mA	Motorola, Teledyne 1N5300
L1, L2	80A253	Ferrite Bead Ring	Stackpole 57-0180
MP2	53A1879B	Grille (Microphone)	None
MP3	37A147	Inner Screen (Microphone)	None
P1	95A8077	Connector, Receptacle, 3-pin Miniature	Switchcraft TB3M
P2	95A247	Connector, Receptacle, 3-pin	Switchcraft D3M
Q101, 105	86A350	Transistor, NPN	Motorola, National Semiconductor 2N5210
Q102,103,104	86A348	Transistor, PNP	Motorola, National Semiconductor 2N5087
S101, 102	55A8031	Slide Switch, SPDT	None
T1	51A286	Transformer	None
W1	C107	Cable and Connector Assembly	None