

General Description

The UA834 provides more flexibility in wireless installations by increasing the allowable length of cable runs between a receiver and antenna. Antennas may be placed closer to the stage, or installed on ceilings and walls that maintain a better line of sight with the transmitter.

Features

- Low-noise signal amplifier compensates for insertion loss in coaxial cable
- Compatible with Shure Wireless Systems. Also may be used with Shure UA845 and UA844 Antenna Distribution Systems

- Integrated threaded adapter mounts easily to microphone stands or the supplied surface-mount bracket
- Two-position gain selector switch
- LED indicator for RF signal overload
- Shure quality, ruggedness, and reliability

NOTE: Antenna amplifiers are intended to compensate for signal loss in cables, not for increasing the range of the antenna. Attempting to “boost” the signal beyond nominal levels only results in overloading the circuit and reducing performance.

Indicators and Settings

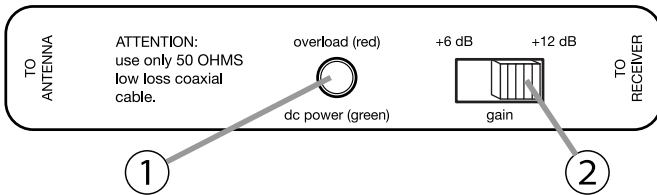

① DC POWER/RF OVERLOAD

Green: Indicates it is receiving power from the antenna input on the receiver or combiner.

Red: Signal from the antenna (at the TO ANTENNA input) is too strong. Remove the inline amplifier or move it further down the cable run.

② GAIN

Set the gain switch to +6 dB for shorter cable runs, and +12 dB for longer runs.

RF Overload

RF overload can occur at the input to the inline amplifier or at the input to the receiver. An overload at either point degrades the signal.

When there is an RF overload indicator on the inline amplifier, the amplifier might not be necessary, or it should be placed further down the cable run at a midpoint between the antenna and receiver. The gain switch only affects output gain, and cannot compensate for input overload at the amplifier.

If there is an RF overload signal on the receiver, reduce the gain on the inline amplifier, or move it further up the cable run so there is more cable between the receiver and the amplifier. Note that the overload level for the amplifier might be greater than that for the receiver input, so it cannot be used to indicate whether the signal will overload the receiver at that point in the cable run.

Installation

Connect between the antenna and receiver (or antenna distribution system), as shown. The DC POWER LED illuminates green when the receiver is powered on.

- Use Shure low-loss coaxial antenna cable (or any 50 ohm, low-loss cable).
- The quality of the cable, not just the length, contributes to signal loss. A lighter grade 50 foot cable may require more gain than a 100 foot, low-loss cable.
- Active antennas, such as the UA874, have a built-in amplifier, and may not require additional amplification.

Caution: Use only Shure antenna accessories to ensure the best operation. Do not use splitters, combiners, or antennas that provide a DC ground. If necessary, use a BNC DC block device (compatible with the receiver RF band).

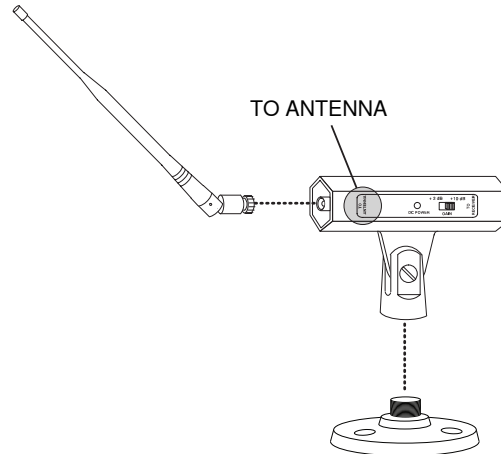

Attach the antenna to the connector labeled TO ANTENNA

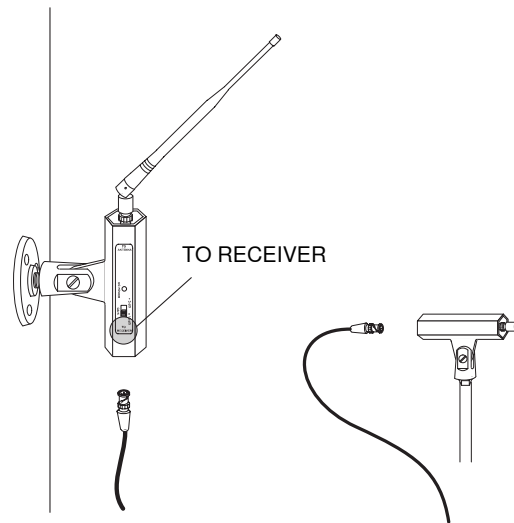

Use the supplied surface-mount bracket on walls or ceilings, or mount on a standard microphone stand.

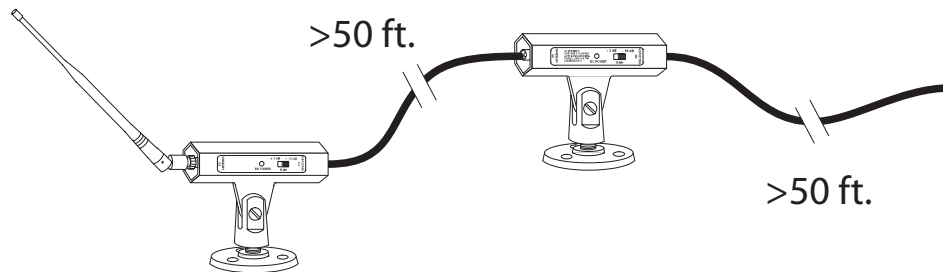

Use a maximum of two in-line antenna amplifiers for extremely long cable runs or for two runs of lighter-grade cable, as shown

Cable Maintenance

To maintain top performance for antenna cables:

- Avoid sharp bends or kinks in the cables.
- Do not deform cables with makeshift clamps, such as bending a nail over the cable.
- Do not use in permanent outdoor installations.
- Do not expose to extreme moisture.

Selecting Antenna Cables

Use 50 ohm low-loss coaxial cable, such as RG-8U. Shure offers pre-terminated antenna cables ranging from 6 to 100 feet.

NOTE: When ordering cables from Shure, select the low-loss "Z" models (available for longer cables) when using frequency bands above 1000 MHz.

Antenna Placement

Use the following guidelines when mounting antennas:

- Antennas and receivers must be from the same band.
- Mount antennas at least one wavelength (two feet) apart.
- Position antennas so there is nothing obstructing a line of sight to the transmitter (including the audience).
- Keep antennas away from metal objects.

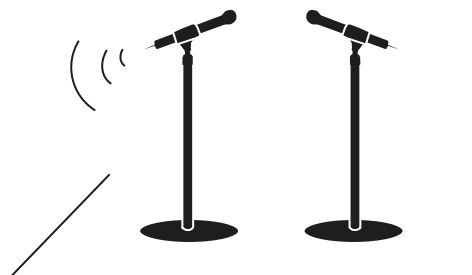

Important: Always perform a "walk around" test to verify coverage before using a wireless system during a speech or performance. Experiment with antenna placement to find the optimum location. If necessary, mark "trouble spots" and ask presenters or performers to avoid those areas.

Find More Information Online

For more information, visit <http://www.shure.com>

Setting Gain

The gain setting should only be used to compensate for the calculated cable signal loss. Additional signal gain does not mean better RF performance. Too much gain actually reduces reception range and the number of available channels. This is because Shure receivers are optimized to deliver the best performance when the sum of signal gain and cable loss equals 0 dB. Additional gain just amplifies everything in the RF range—including interference and ambient RF noise. It cannot selectively increase the signal from the transmitter.

- Use the lowest gain setting necessary to achieve good reception of the transmitter RF signal, as indicated on the receiver's RF LED or meter.
- Only increase the gain setting to compensate for the calculated cable loss.

- The resulting signal level at the receiver (cable loss plus amplification) should be within ±5 dB of the original signal level at the antenna.

Calculating Gain Settings

To calculate the required gain setting, obtain the cable manufacturer's specification for signal loss. The rated loss usually varies with RF frequency in addition to cable length.

Multiply the per 100 feet rating of the cable by cable length to determine signal loss, and add gain as necessary to compensate. For example: a 50 ft. cable with rated loss of -12dB per 100 ft. would calculate as $(-12\text{dB}/100) * 50 = -6\text{dB}$ and require +6dB of gain for a sum total of 0 dB loss.

Specifications

Frequency Range

UA834V	174–216 MHz
UA834WB	470–902 MHz
UA834XA	902–960 MHz
UA834Z16	1240–1260 MHz
UA834Z17	1492–1525 MHz
UA834Z18	1785–1805 MHz

Connector Type

BNC, Female

Impedance

50 Ω

Power Requirements

10 to 15 V DC bias from coaxial connection, 0.60–0.72 W

Signal Gain

±2 dB, Switchable

+6 dB +12 dB

Absolute Maximum RF Input

+5 dBm

RF Overload LED Threshold

±2 dB

-5 dBm

Input Third-Order Intercept Point (IIP3)

>10 dBm

Housing

Cast Aluminum, black painted finish

Dimensions

67 x 32 x 112 mm (H x W x D) Dimensions with Stand: 108 x 32 x 112 mm

Net Weight

Without Mounting Stand	0.28 kg (9.8 oz.)
With Mounting Stand	0.42 kg (14.8 oz.)

Certifications

This product meets the Essential Requirements of all relevant European directives and is eligible for CE marking.

The CE Declaration of Conformity can be obtained from:
www.shure.com/europe/compliance

Authorized European representative:
Shure Europe GmbH
Headquarters Europe, Middle East & Africa
Department: EMEA Approval
Jakob-Dieffenbacher-Str. 12
75031 Eppingen, Germany
Phone: 49-7262-92 49 0
Fax: 49-7262-92 49 11 4
Email: info@shure.de